

# **TDP/NJI ABSMaster**

## **Automatic Block Signal Controller**

You have purchased the TDP ABSMaster, a four block ABS (Automatic Block Signal) controller. With it you will be able to control up to four consecutive block signals on your railroad. It is expandable to as many blocks as you want. It will work with all 'light' signals (for semaphore signals see our ServoMaster products). Three light, two light and searchlight style signals are supported. The ABSMaster Includes optical block occupancy detection (IR reflective sensors are an option). It will also work with third party block detection. If you want to signal a bi-directional track you will need one ABSMaster for each direction. The ABSMaster is designed to work with LED based signals. Incandescent light signals may require additional external circuitry depending upon the voltage and current required by the lamps. Position light signals can be accommodated if the LEDs are wired in parallel.

### **Contents of the Kit**

- ABSMaster Board
- 4 Signal/sensor cables (Optical or IR)
- One sensor cable (Optical or IR)

### **Power Requirements**

The ABSMaster requires a power supply of 7V – 18V AC or DC capable of supplying 300 ma (the auxiliary terminals of your power pack or a wall transformer will work).

### **Precautions**

Care must be taken to ensure that you do not short out the ABSMaster board or the sensors during installation. Do not place the circuit board on the rails when you are working on it, and make sure that the rails are not powered when installing the sensors. Touching a sensor or the ABSMaster board to a powered rail will probably damage the sensor and/or the ABSMaster board.

# Connections

The connections for the ABSMaster board are shown in figure 1. When installing the supplied signal cables and the TOC cable be sure to install the connector over both rows of pins, and make sure that the red stripe on the wire is toward the '1' printed on the circuit board.

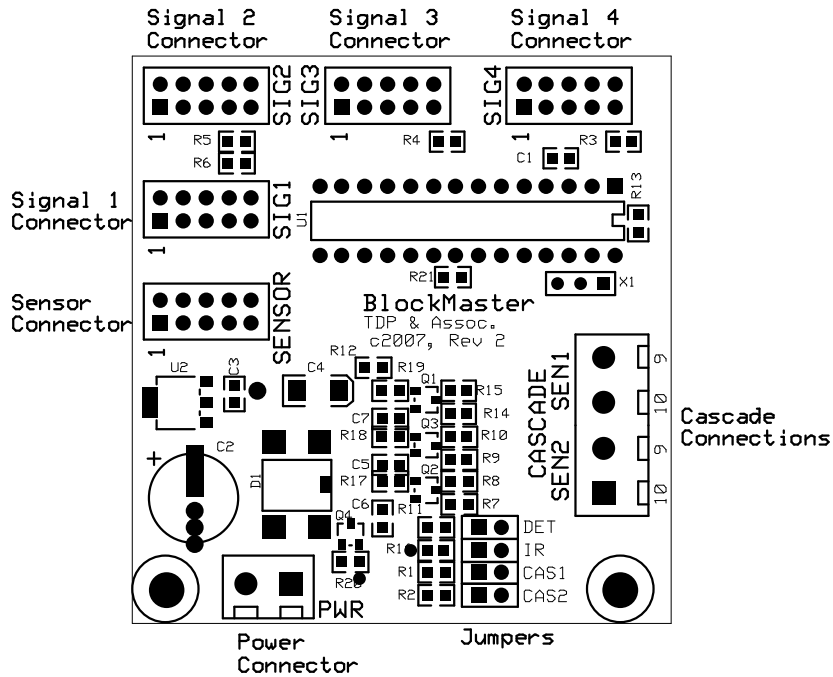

Figure 1

# Setup

The ABSMaster provides detection and control for four consecutive two or three aspect block signals orientated in one direction of travel. To do this five track blocks are needed. Figure 2 shows the normal block and signal layout for the ABSMaster when using the supplied sensors. The blocks are labeled from 1 to 5. Above the block name the relationship of that block to the signals is listed. For example, block 3 is the 'red' block for signal 3 and also is the 'yellow' block for signal 2. A 'red block' is the block, that when it is occupied,

# Block Layout

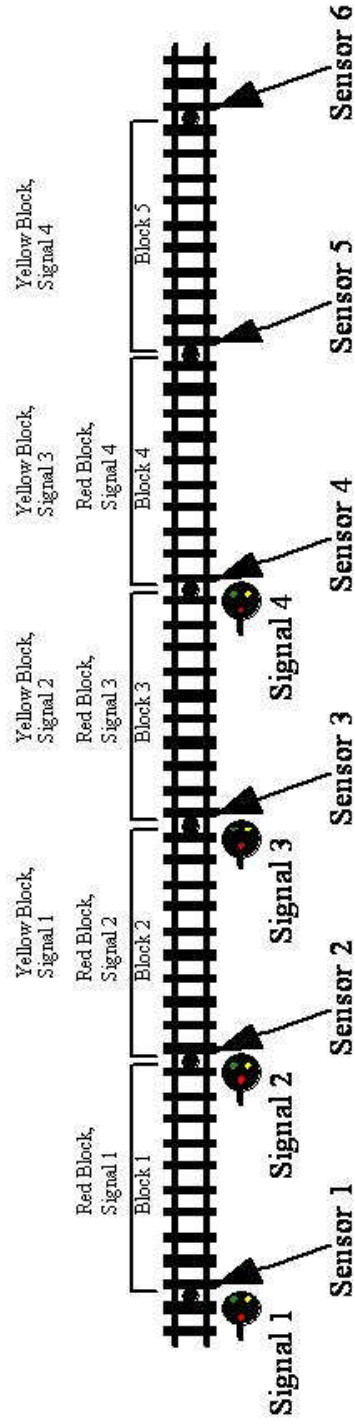

Figure 2

will cause the associated signal to turn red ('stop'). A 'yellow block' is the block that will cause the associated signal to show the yellow or 'approach' aspect. If the train is passing between the red block and yellow block the signal will display the red (stop) indication. So, to allow signal 4 to function correctly an additional block (block 5) needs to be detected to allow the yellow aspect to be properly displayed. This extra block is defined by using either a 'triple optical sensor' (TOC) cable or by using the cascade inputs (wires 9 & 10) from the first two signal cables from a second ABSMaster board (used for installations that have more than four signals in one direction).

Each signal cable has one sensor installed on it. It also contains the connections for the signal itself and optional connections used to 'cascade' two ABSMasters together for installations that have more than 4 signals in one direction. The sensor is to be placed a short distance after the signal as shown in figure 2. Covering this sensor will cause the signal to show a 'stop' indication. A 'block' is defined as the track section between two of the sensors. So, block 1 is defined between the sensor on signal cable 1 and signal cable 2. The ABSMaster will detect which direction a train is moving and display the proper signal indications (either in the 'normal' direction from which the signals can be seen or 'reverse' direction where the fronts of the signals will not be seen by the train). The wire assignments are given in Table 2. The sensor is pre-installed on the cable. You will need to drill a hole between the rails, through the roadbed and sub-roadbed using a #20 drill bit or a 3/16" drill bit for the standard optical sensors. IR sensors require larger holes (about 5/16" or 8mm) which will require the removal of at least one tie in N and HO scales. You then insert the sensor up from beneath the layout until the sensor lens is even with the tops of the ties (NOT the rails!). If you have the IR sensor option you will need to remove the IR jumper (see Figure 1 and Table 1). All other setup is the same as for the optical sensors except where noted.

In full four signal installations an additional sensor cable is used to define the end of block 4 and both ends of block 5. These blocks are necessary to allow the proper operation of signals 3 & 4. TDP offers a 'TOC' (triple optical cable) for this. You will need only two of the three sensors on the TOC. Use the sensor closest to the red stripe as 'Sensor 5' in figure 2 and the sensor in the center of the cable for 'sensor 6' in figure 2.

In installations that have more than four signals you will only need one TOC. Connect the cascade wires from the second ABSMaster's 'Sig 1' cable to the Cascade terminal blocks 'Sen 1' terminals (the numbers printed on the board correspond to the wire to be connected from the signal cable, wires 9 & 10) and connect the cascade wires from the second ABSMaster's 'Sig 2' cable to the cascade terminal blocks 'Sen 2' terminals (see figure 3). You must also remove the 'CAS1' and 'CAS2' jumpers from the ABSMaster board (see figure 1). Any number of ABSMaster boards can be cascaded together for continuous ABS installations.

See the 'Signal Wiring' section for the details on how to connect the signal's wires to the ABSMaster's signal cables. Note that for two light and/or searchlight signals you will need to connect two wires of each cable together so that the ABSMaster will be able to tell what kind of signal you have hooked up. For example, for a two light common cathode signal you will need to connect wires 1 & 3 together on the signal cable, in addition to connecting the signal's wires to the correct wires on the signal cable.

The ABSMaster can operate with third party detectors, such as current sensing detectors commonly used on DCC controlled layouts. To use third party detectors you will need to determine whether the block detectors will give you a 'high' or a 'low' for an occupied block. If the block detector's output gives you a voltage greater than 1.5V (but less than 5.0V) when a train is in the block then this detector is a 'high' detector. If the detector gives you a voltage of less than 1.0V for an occupied block then it is a 'low' detector. An example of a 'low' detector is the Northcoast BD20. An example of a 'high' detector is the Digitrax BDL16/162/168, which has auxiliary outputs that can be used to drive the ABSMaster. Once you have determined whether you have 'high' or 'low' detectors you can set the jumper on the ABSMaster according to table 1.

| Detection type  | IR Jumper | DET Jumper |
|-----------------|-----------|------------|
| Optical         | Out       | Out        |
| IR              | In        | Out        |
| External 'low'  | Out       | In         |
| External 'high' | In        | In         |

Table 1

# Multiple BlockMaster Hookup

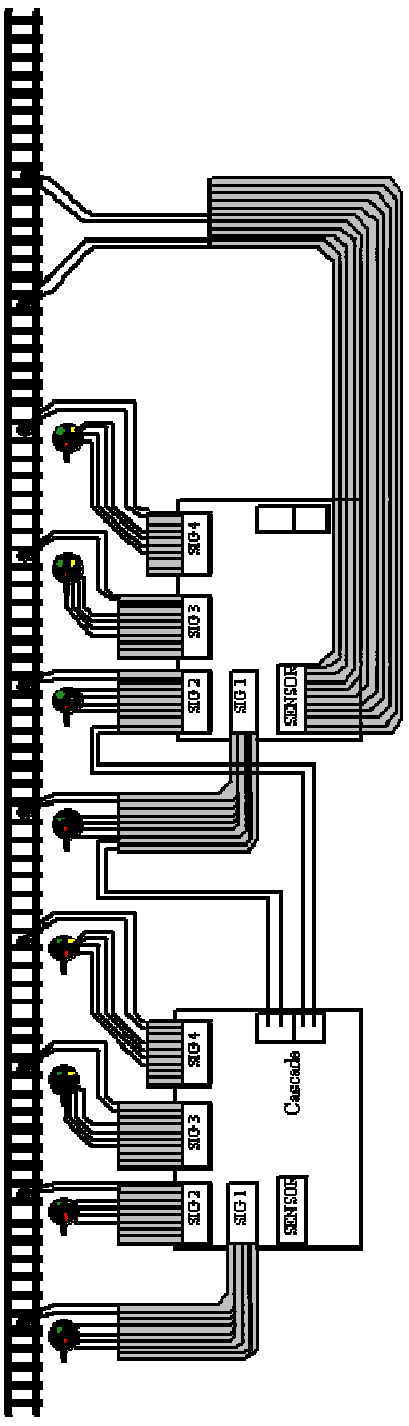

Figure 3

## Signal cable connections

| Pin | Signal  | Description   |
|-----|---------|---|
| 1   | +5V     | Common connection for common anode signals            |
| 2   | Green   | 'Green' signal light connection                       |
| 3   | Yellow  | 'Yellow' signal light connection                      |
| 4   | Red     | 'Red' Signal light connection                         |
| 5   | Gnd     | Common connection for common cathode signals          |
| 6   | Flash   | Connection for IR sensor IR source                    |
| 7   | GND     | GND connection for sensors                            |
| 8   | Sensor  | Connection for sensors and/or external block detector |
| 9   | Cascade | Cascade output for expansion                          |
| 10  | GND     | Cascade GND for expansion                             |

Table 2

## Signal wiring

The ABSMaster will detect what kind of signals you have provided that you follow the wiring instructions given in the tables below. You can mix and match signals however you want (two light, three light, searchlight, common cathode and/or common anode). If you do not know if your signals are 'common anode' or 'common cathode' you will need to test them. Simply stated 'common anode' means that the positive leads of the LEDs are connected together to the common wire on the signal. 'Common cathode' means that the negative leads of the LEDs are connected together to the common wire of the signal. Most commercially available signals will come with dropping resistors already installed on the signal leads. If your signals do not have resistors you will need to purchase them. Do not connect the signals up to the ABSMaster without a dropping resistor on each lead (no resistor is needed on the common lead). A good starting value for the dropping resistors is 1000 ohms (commonly called a 1K resistor, color coded brown-black-red). Some signals will have resistors that are too large to work correctly with the ABSMaster. These signals have their resistor values chosen for working with 12V or more. The ABSMaster uses 5V to light the signals. You will need to replace these resistors with smaller value resistors if the LEDs do not light up bright enough.

The easiest way to test the signals will be to power up the ABSMaster and use the +5V (pin 1) and GND (pin 5) wires on one of the signal cables to test the signals. Strip a small amount of insulation off these two wires, taking care not to short these wires together. Take the common wire from your signal and connect it to +5V (pin 1). Take one of the signal leads (these will usually be color coded red, yellow or green and will have the dropping resistor installed on them) and touch it to the GND (pin 5) wire. **MAKE SURE THAT THERE IS A DROPPING RESISTOR ON ONE OF THE WIRES OR YOU WILL DAMAGE THE SIGNAL!!** If the LED turns on then the signal is common anode. If the LED does not light then reverse the connections (common wire to GND & signal lead to +5V). If the LED lights then your signal is common cathode. If the LED did not light (or lit too dimly) then either the signal is bad or the resistor is too large.

In the case of a two lead searchlight signal the LED will light with the leads connected either way. In this case you need to note which wire is positive and which wire is negative when the red LED is lit. Match these wires to the entries in the table for the two wire searchlight signals when you connect the two wire searchlight signal.

Another note on searchlight signals. They are built with bi-color LEDs. That is, they have both a red and green LED in the signal. Most of these signals will have three leads, a common lead, a red lead and a green lead. To make 'yellow' both LEDs are turned on. However, due to differences between the red and green LEDs you may not get a pure yellow (most times the red LED will overpower the green LED. If your searchlight doesn't give you a good yellow you can play with the resistor values on either the red or green wire to 'balance' the LEDs to give you a good yellow. For example, if the color is too red (meaning the red LED is overpowering the green LED you can increase the value of the resistor on the red lead, which will dim the red LED giving you a better looking yellow signal. In the case of a two wire searchlight signal making 'yellow' is more complicated. In this case the ABSMaster needs to reverse the polarity on the two signal wires at a fast rate (that the eye cannot see) to make it look yellow. We have chosen a reasonable rate but due to the variations between various LEDs you may not get a good yellow. In this case changing the resistors will not help much. If your two lead searchlight signals do not produce a good yellow contact TDP for other options.

### Three light common anode signals

|                            |              |
|----------------------------|--------------|
| Signal wire for Green LED  | 2 – 'Green'  |
| Signal wire for Yellow LED | 3 – 'Yellow' |
| Signal wire for Red LED    | 4 – 'Red'    |
| Signal wire Common         | 1 – '+5V'    |

### Three light common cathode signals

|                            |              |
|----------------------------|--------------|
| Signal wire for Green LED  | 2 – ‘Green’  |
| Signal wire for Yellow LED | 3 – ‘Yellow’ |
| Signal wire for Red LED    | 4 – ‘Red’    |
| Signal wire Common         | 5 – ‘GND’    |

#### **Two light common anode signals**

|                           |             |
|---------------------------|-------------|
| Signal wire for Green LED | 2 – ‘Green’ |
| Signal wire for Red LED   | 4 – ‘Red’   |
| Signal wire common        | 1 – ‘+5V’   |
| ABSMaster wire 3 (Yellow) | 5 – ‘GND’   |

#### **Two light common cathode signals**

|                           |             |
|---------------------------|-------------|
| Signal wire for Green LED | 2 – ‘Green’ |
| Signal wire for Red LED   | 4 – ‘Red’   |
| Signal wire common        | 5 – ‘GND’   |
| ABSMaster wire 3 (Yellow) | 1 – ‘+5V’   |

#### **Searchlight signal with three leads, common anode**

|                           |              |
|---------------------------|--------------|
| Signal wire for Green LED | 3 – ‘Yellow’ |
| Signal wire for Red LED   | 4 – ‘Red’    |
| Signal wire common        | 1 – ‘+5V’    |
| ABSMaster wire 2 (Green)  | 5 – ‘GND’    |

#### **Searchlight signal with three leads, common cathode**

|                           |              |
|---------------------------|--------------|
| Signal wire for Green LED | 3 – ‘Yellow’ |
| Signal wire for Red LED   | 4 – ‘Red’    |
| Signal wire common        | 5 – ‘GND’    |
| ABSMaster wire 2 (Green)  | 1 – ‘+5V’    |

#### **Searchlight signal with two leads**

|                              |              |
|------------------------------|--------------|
| Positive Signal wire for Red | 3 – ‘Yellow’ |
| Negative Signal wire for Red | 2 – ‘Green’  |
| ABSMaster wire 4 (Red)       | 5 – ‘GND’    |

## **Operation**

The ABSMaster will operate prototypically when a train is traveling in either direction on the track that is signaled with the ABSMaster. The optical sensors define the track blocks. These blocks are shown in figure 2. If there are no trains in any of the blocks all signals will have a green or ‘clear’ indication. Forward movement (when the train is traveling in the direction that the engineer can see the signal indications) proceeds like this. The train ‘sees’ the first signal’s green indication and proceeds down the track. As the train covers the first sensor (sensor 1 in figure 2) signal 1 will change to a red indication (stop). At this time the ABSMaster determines what direction the train is traveling in. As the train reaches the next signal the engineer will see that this signal is green too, and continue down the track. As the train covers sensor 2 the second signal will change to red. So, now both signals that the train has passed are red. Once the end of the train passes the second signal and uncovers sensor 2, signal 1 will change to yellow. When the end of the train passes the third signal and uncovers sensor 3 then the first signal will change to green and the second signal changes to yellow. This sequence will continue as the train travels down the track. A train can follow the first train by riding the yellow signals behind the first train. In the case of a train running in the reverse direction as the train covers sensor 6 (in figure 2) signal 4 will show red and signal 3 will show yellow. When the train covers sensor 5 signal 3 & 4 will show red and signal 2 will show yellow. This sequence will continue as the train travels down the track. As the end of the train passes each signal that signal will switch back to green.

The ABSMaster has a built in timeout feature that will reset the signals if it detects no movement for about two minutes. The timeout will cause the signals to reset to green if no sensor is covered for two minutes after one of the sensors has been tripped (has something pass over it). For example, if someone waives a finger over one of the sensors the signals associated with it will switch to red and/or yellow. This should cause any trains approaching the signal to stop and wait for a green or yellow indication so that it may proceed. But, since a train did not cause the block to be occupied the signal will stay red. The timeout feature was added to allow the ABSMaster to recover from any false triggering of its sensors. However, there is a downside to the timeout feature. If you are running short passenger trains and there is a station within one of the detected blocks, the station stop may be long enough to have the timeout feature reset the signals to green, thus allowing a following train to run into the rear of the passenger train! So, when placing

the sensors and signals try to place a signal/sensor at a point near the station where the stopped train will be covering the sensor. This will prevent the timeout feature from resetting the signals.

Another thing that the timeout feature was added to correct is what happens when you power up your layout while a train is within one of the blocks defined by the ABSMaster. In this case the ABSMaster doesn't know which way the train is traveling. The signals in the direction the train is traveling should work correctly, allowing the train to proceed, but, the signals that are 'behind' the train will behave as if the train was running in the reverse direction. Since no train is traveling in that direction the signals will stay red until the timeout feature resets them to green after about two minutes.

The ABSMaster also has a built in 'debounce' feature. This feature requires a sensor to be covered or uncovered for about a second before it is recognized as having changed states. This prevents the spaces between the cars from causing a false clearing of a block as the train is moving. It also prevents a passing shadow (of a hand or other passing object that is not on the tracks) from causing the signals to change unless it keeps the sensor covered for a second.

## Sensors & Troubleshooting

Optical sensors need light to work properly (you cannot run in the dark!). The sensors respond to incandescent lights the best, but fluorescent lighting works quite well too. However, the location of the lighting is very important. For example, on a two track railroad, if the lighting is coming from one side of the tracks a passing train may shade the second track causing a false occupancy. In this case it is best to place the lighting directly above the tracks. Another example of a lighting problem is if the lighting comes from the isles. The sensors will work just fine most of the time, but may trip when a tall person walks by (something I do not need to worry about).

One might think that using IR sensors will fix these problems, but IR sensors have their own set of issues. They will work in the dark, but could have trouble when the lights are on. The ABSMaster uses an algorithm to try to avoid this, and on the whole it works quite well. But, in cases where there is not quite enough visible light to cause the IR sensor to 'wash out' (cause the photo transistor to turn 'on'), when the IR source is turned on any slight reflection (like from the ceiling) will cause a false occupancy indication. In this case it may be necessary to move the lighting around so that the sensors have either more or less light on them (either case, lots of light or no light is OK, it is the 'in between' case that is a problem). The other issue with IR sensors is that they have a limited range of detection. They will work with N and HO scales, but larger scales may be a problem. In HO scale, frameless tank cars with black bottoms are hard to detect. The curve of the tank causes the IR energy to be reflected away from the sensors, and black doesn't reflect all that well either. If the train is moving fast enough this won't be a problem as the trucks & couplers will provide enough reflection, such that the one second delay mentioned in the operation section will keep the block occupied. But, as these tank cars tend to be very long, if the train is moving slowly the ABSMaster may become confused. If the ABSMaster does become confused it will correct itself in about two minutes after all the sensors are uncovered. One other minor abnormality of IR sensors is that they will show up as a bright blue-white light on those little in-train video cameras.

If you power up the ABSMaster after installing all the sensors and any of the signals come up red, check all the jumper settings on the board.

In the case of optical sensors, if any of your signals come up red when you power the ABSMaster up when all sensors are uncovered this is an indication that there isn't enough light on at least one sensor. Flashlight(s) can come in handy to determine which sensor(s) are causing the problem. This could also be caused by a signal cable being left unplugged, or if the cable is plugged in incorrectly.

In the case of IR sensors, if any of your signals come up red when you power the ABSMaster up when all sensors are uncovered this could be an indication that your ambient lighting is in the 'borderline' area as was described above. To check this, turn the layout lighting off and cycle the power on the ABSMaster. If any signals still come up red then the most likely problem is that an IR sensor is picking up a reflection from somewhere, such as the upper deck of the layout, the ceiling or the signal bridge (if you are using signal bridges for your signals). In this case the area above the IR sensor should be painted black. If this still doesn't work contact TDP for suggestions on how to reduce the sensitivity of the IR sensors.

## WARRANTY INFORMATION

TDP & Associates guarantees the ABSMaster to be free of component and manufacturing defects for a period of one year after date of purchase. If a defect occurs return the product to TDP & Associates for service. TDP & Associates will repair or replace the ABSMaster at its discretion at no charge during the warranty period. This warranty excludes damage due to abuse, such as but not limited to failure to properly install the unit, applying excessive input voltage to the unit or failure to provide protection against input over current with a fuse or circuit breaker.

TDP & Associates will make non-warranty repairs to the ABSMaster at reasonable and fair rates.

All warranties on this product are limited to refund of purchase price or repair or replacement of this product at the sole discretion of TDP & Associates.

In the event that this product is not installed or used in accordance with the manufacturer's specifications any and all warranties either expressed or implied are void. Except for what is expressly stated in this section there are no warranties, express or implied, including but not limited to any warranties of merchantability or fitness for a particular application.

TDP & Associates, Inc. reserves the right to make changes to this product's design or specifications, and/or to make improvements to this product, at any time, without obligating TDP & Associates to install these changes, additions or improvements on previously manufactured products.

## CONTACT INFORMATION

TDP & Associates, Inc.

4 Jones Drive  
Boothwyn, Pa. 19061  
(610) 358-0460

[www.trainspeed.com](http://www.trainspeed.com)

Email (preferred):  
[support@trainspeed.com](mailto:support@trainspeed.com)

©2006, TDP & Associates, Inc.

Ver. 1.0