

TrainSpeed 4

Model Railroad Speedometer

Operating Manual

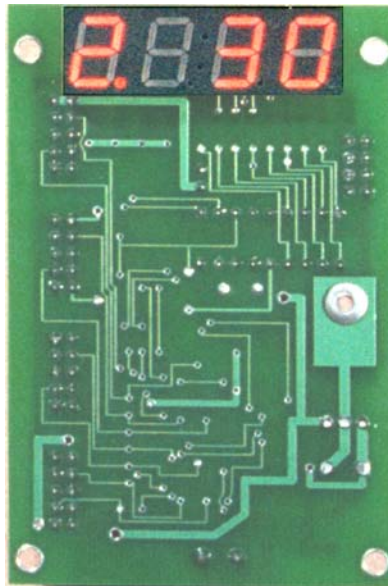

TDP & Associates, Inc.
(610) 358-0460
www.trainspeed.com

TrainSpeed 4 Operating Instructions

TrainSpeed 4 will give you a reasonably accurate scale speed indication for your trains at four points along your model railroad. The maximum speed measurable is 999 Mph (or Kph) and the minimum speed measurable is 1 Mph (or Kph). It can be used to match speeds in MU lashups or be used to ensure that track speed limits are obeyed during operating sessions (beware that our younger model railroaders may use it to see just how fast they can go!).

Installation

The unit is designed to be mounted to your control panel or behind the façade of the layout. A rectangular hole needs to be made in either the façade or the control panel along with four #4 screw clearance holes. If you are using a clear plexiglass control panel then you can mount the unit behind a clear window instead of cutting a hole in the panel. The layout for these holes are shown on the included full sized drill template.

The unit may be configured to measure the train's speed over 1/50, 1/100, 1/200 or 1/400 of a scale mile (or Km). The sensor spacing for most scales can be found in following tables (table 1 for miles and table 2 for Km).

For example, in N scale if you use the 1/100 scale mile interval, you need to place the sensors 3.96 inches apart. If your particular scale is not listed you need to calculate the proper interval by dividing 63360 (the number of inches in a mile) by your scale's ratio, and then dividing that result by the interval chosen (50, 100, 200 or 400). The unit is configured for 1/100 of a mile at the factory.

Table 1

scale	ratio	Scale mile (in)	1/50 mile	1/100 mile	1/200 mile	1/400 mile	
Z	220	288.000	5.760	2.880	1.440	0.720	In
N	160	396.000	7.920	3.960	1.980	0.990	In
HO	87	728.276	14.566	7.283	3.641	1.821	In
OO	76	833.684	16.674	8.337	4.168	2.084	In
O	48	1320.000	26.400	13.200	6.600	3.300	In
S	64	990.000	19.800	9.900	4.950	2.475	In
G	24	2640.000	52.800	26.400	13.200	6.600	In
TT	120	528.000	10.560	5.280	2.640	1.320	in

Table 2

scale	ratio	scale km (cm)	1/50 km	1/100 km	1/200 km	1/400 km	
Z	220	454.55	9.09	4.55	2.27	1.14	cm
N	160	625.00	12.50	6.25	3.13	1.56	cm
HO	87	1149.43	22.99	11.49	5.75	2.87	cm
OO	76	1315.78	26.31	13.16	6.58	3.29	cm
O	48	2083.33	41.67	20.83	10.42	5.21	cm
S	64	1562.50	31.25	15.63	7.81	3.91	cm
G	24	4166.67	83.33	41.67	20.83	10.42	cm
TT	120	833.33	16.67	8.33	4.17	2.08	cm

The accuracy of the unit depends upon how precisely the sensors are spaced. For example, for N scale and the 1/100 interval, from table 1, 3.96 inches should be used. 4 inches will give you about a 1% error in the speed reading. The 1/50 of a mile setting this same measurement error (0.04 in) will give only a 0.5% speed error. Sensor spacing errors can be minimized by choosing the longest spacing that is practical for your layout and scale (for example, 1/50 of a mile in O scale is over 2 feet which is a bit impractical, while at 5.76 inches it would be ideal for Z scale).

Sensor placement

All four sensor pairs of the TrainSpeed 4 must use the same spacing. The sensors are designed to use available ambient light. Mounting them in tunnels or dark corners of the layout is not recommended. It is best to pick a well lit section of the layout where the light source comes from above and 'inside' the layout. If the light source is 'outside' the layout a person walking by may trigger the unit. The included sensor cables are ten feet long. Cable extensions can be purchased or made. The TrainSpeed 4 display unit will work with cables as long as 30 feet. See the appendix for cable extension construction.

Note that you do not need to use all four sensors if you do not need them. The unit will figure out which sensors are missing and only use the sensors that are connected.

Using a #20 drill bit (5/32" also works but is a bit tighter), drill the sensor holes through your roadbed and sub-roadbed to the chosen spacing (watch out for switch machines and the like under the layout when choosing the location of the sensors). Make sure that the edges of the holes are 'clean', especially on the bottom as this will make sensor insertion much easier. The sensors should then be inserted into the holes from the bottom and pushed up until the top of the sensor is flush with the top of the ties. **Warning: Power to the rails should be off when inserting the sensors, especially if you are using DCC.** An insertion tool can be made out of small tubing by cutting a slot in the tubing to provide clearance for the wires. This tubing can then be used to push the sensor up through the hole to avoid damaging the wires. If you are having trouble getting the sensor through the roadbed use a larger drill bit (the #20 and/or 5/32" bits provide a 'press fit' for the sensors that will usually hold them in place without any adhesive or tape). Make sure the sensors do not exceed the railhead height as you will damage them the next time you clean the rails with an abrasive rail cleaner. If needed the ribbon cable can be split easily for wider sensor spacing. The sensors can be held in place by tape over the bottom of the hole. If you must glue them in place, be sure to use a water based, clear drying glue.

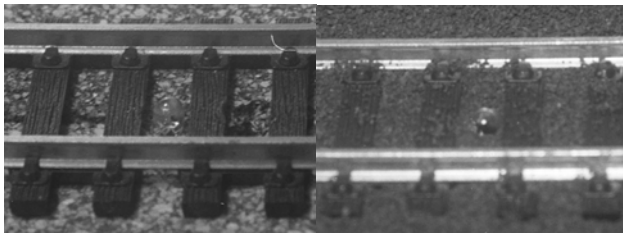

Connect the sensor cables to the TrainSpeed 4 unit on connectors J1, J2, J3 and J4, being sure to align the red stripe on the cable to the pin 1 marking on the TrainSpeed board (see figure 1).

Do not use staples to hold the cables in place as they can cut the insulation and cause shorts. If you must anchor the cables to the benchwork, staple a cable tie to the benchwork and then wrap the cable tie around the sensor cable.

You now need to configure the TrainSpeed's jumpers to use the sensor spacing selected from the previous tables. The factory configuration is set to 1/100 of a mile (or Km). Using this table set the option jumpers for the chosen sensor spacing.

Operating modes	0	1	2	3
jumper	1/50	1/100	1/200	1/400
1	Out	in	out	in
2	Out	out	in	in
3	Out	out	out	out
T	Out	out	out	out

‘In’ means that the jumper is install across the two posts while ‘out’ indicates that this jumper is removed (or installed on a single post so you do not loose it).

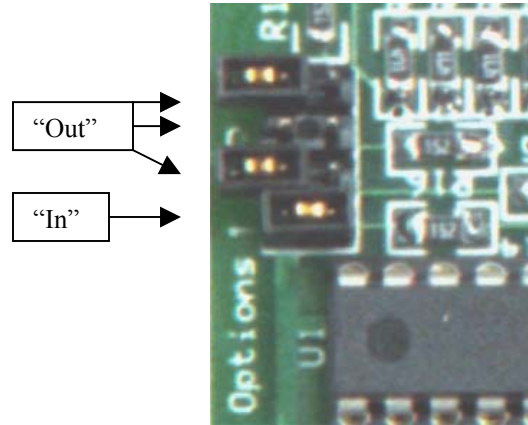

Once the unit is configured you may connect the power to it. You may use your power pack’s auxiliary AC or DC terminals to power the TrainSpeed board, or you may elect to use a wall transformer (see the appendix for wall transformer specifications). The unit needs at least 6V to operate correctly and the supply voltage should not exceed 18V (AC or DC). The unit requires less then 100ma current to function. The wires from your power source should be connected to J5, the two screw terminals on the board (polarity for DC supplies doesn’t matter). If you are using a supply that does not have overload protection (most powerpacks have this) you should insert a ½ amp fuse in supply line. Fuses and fuse holders are available at Radio Shack. This should complete the installation of the TrainSpeed 4 unit.

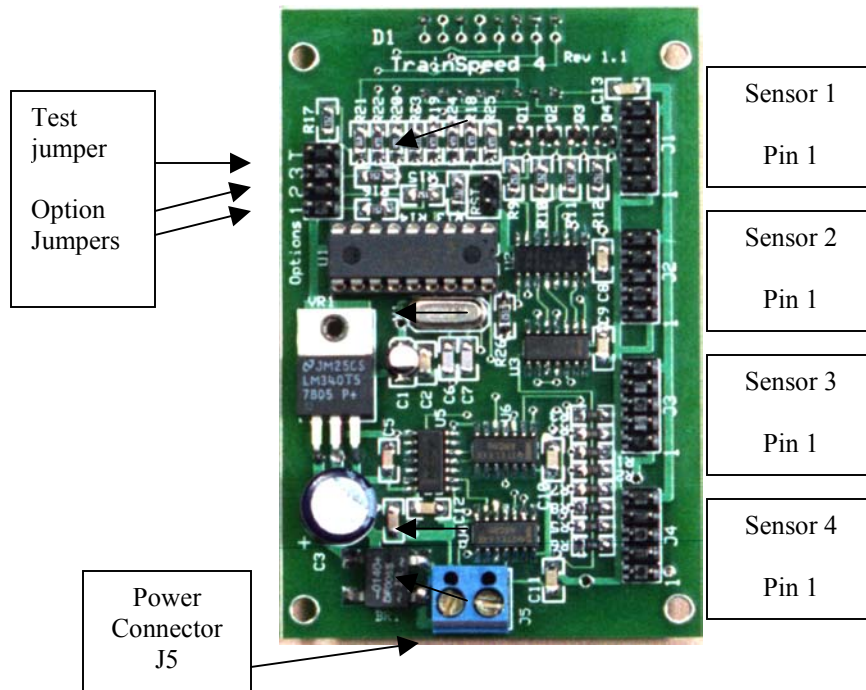

Figure 1

Operation

When power is applied to the TrainSpeed unit, it will display the jumper settings for a short time by displaying oP.x where 'x' is the jumper setting shown in table 3.



After about 2 seconds, if all is connected correctly, the display will show 4.3.2.1 indicating that all sensors have been detected correctly.



If one (or more) of the numbers is missing, and that sensor pair was installed, then there is a problem with that sensor pair. For example, if sensor pair 2 was not connected or connected incorrectly the display would look like this:

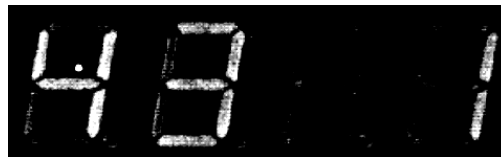

At power-up the unit will scan the four sensor pairs. It expects all eight sensors to be 'seeing' light. If any sensor indicates that it is 'dark' (common causes can be a train parked over it, the sensor fell out of the hole or the connector is not installed correctly) that sensor pair's number will be blank in the above display. If the missing sensor pair(s) were installed and are uncovered, see the troubleshooting section. If you had parked a train over the sensor (or left this manual lying over it) the unit will begin scanning the sensor as soon as the error condition is corrected, though this display will not change. The unit will work correctly for the sensors listed in this display, so you may test the overall functionality of the TrainSpeed 4 if you want to before troubleshooting a bad sensor. As a test, try tripping the sensors with your finger exactly 1 second apart. The display should then read 36 if you are using the 1/100 of a mile sensor spacing (72 for 1/50, 18 for 1/200 and 9 for 1/400). If the speed is off a bit you need to check your own 'timing'. When the first sensor is tripped the display will show which sensor is activated in the first digit of the display with the rest of the display blank. Once the second sensor is tripped you will see the scale speed displayed on the unit.



This shows that sensor #2 was activated and the train (or finger) was doing 30 Mph. The speed will remain in the display until either this sensor or another sensor is triggered. If this test works you are ready to start running trains!

The unit is capable of reading only one sensor pair at a time. So, if you are running a multi-track layout and two trains hit the sensors at almost the same time then the first train to trip the sensors will be the one has its speed measured. The other train will be ignored. It should also be noted that a sensor pair will be disabled for about 2 seconds after the train has passed it before it will be able to measure another train's speed. This was done to avoid false triggering as the spaces between cars in a train cross the sensors.

Error messages

There are three error messages that can be displayed during normal operation. If you get a display of Er.F it means that the train was moving faster then 999 mph.

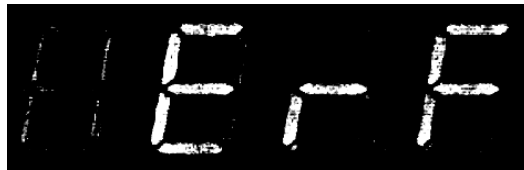

The message Er.S indicates that the train was moving slower then 1 mph.

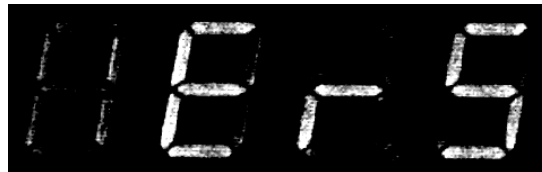

You will see the Er.S message if you have inadvertently tripped one of the sensors by throwing a shadow over it while working on the layout (on dimly lit layouts just walking by could cause this). It takes about two minutes (on the 1/100 jumper setting) for this message to be displayed. The unit will display normal speed for the next train whenever any of these errors occur.

If the message Er.1 is displayed it means that both sensors were tripped at the same time. The probable cause is turning out or blinking the lights, disconnecting a sensor cable or a really, really fast train (or finger). When this occurs the unit will reset after about 2 seconds and normal operation will resume.

Troubleshooting

The most common problem is a missing sensor at power-up. This means that the unit did not detect the sensors correctly. Several things may cause this. The cable could be plugged in incorrectly (or not at all), the sensors are 'in the dark' (make sure a train is not parked over the sensors), a sensor fell out of the hole or a wire is broken. If your layout is powered up by one switch that powers the lights as well as the TrainSpeed 4 power source, you may get missing sensor errors. The unit in this case should operate normally even though the missing sensor error occurred.

If you want to verify the sensors in this case you will need to power down and power up the TrainSpeed board to initialize it correctly.

One common occurrence with the connector used is that only one row of pins is covered by the connector

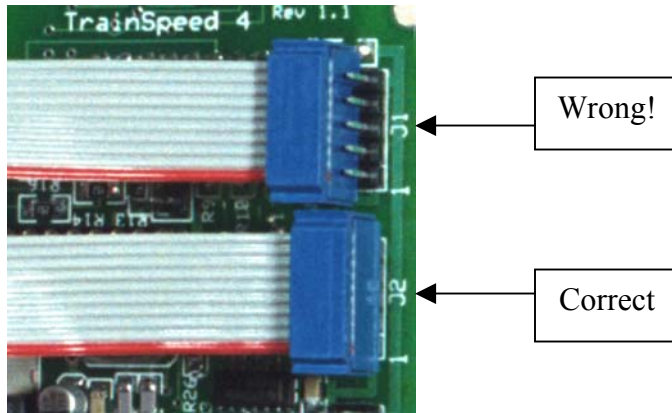

If you are sure that the wiring is correct then you should use the test mode to see if one or both of the sensors are operating correctly. Do this by powering down the unit and removing all jumpers. Install one jumper on the pair of pins marked 'T'. Apply the other jumpers as shown in this table

Option Jumper	1	2	OP.x
Sensor 1 displayed	Out	Out	0
Sensor 2 displayed	In	Out	1
Sensor 3 displayed	Out	In	2
Sensor 4 displayed	In	In	3

Apply power to the unit. You should see the jumper option message 'oP.x'. Then you will see one of the following displays:

L.y.L => both sensors are working correctly

H.y.H => both sensors are either disconnected or 'in the dark'

H.y.L or L.y.H => one sensor is 'dark' while the other is not.

Where y is the sensor selected by the jumper settings. For example, if sensor 2 is selected and it is working properly you will see:



If sensor 3 was selected and one of the sensors was 'dark' (indicated by 'H') the display would look like this:



When a sensor is covered ('in the dark') the test display for that sensor should read 'H'. When the sensor is lit you should see an 'L' in the test display. For the unit to power up properly both sensors should be lit (displaying 'L'). If you are getting an 'H' for a sensor, try shining a flashlight on the sensor to see if it switches to 'L'. If this works then you should either add some additional lighting to your layout at that point or move the sensors to a better lit location. If you have marginal light at this location you can sometimes get the sensor to work if you push it up a little further through the roadbed (do not exceed the railhead height!).

If the lighting appears to be OK but a sensor is still 'in the dark', try swapping cables with a working set of sensors (power down the unit before swapping cables). If the other set of sensors work, then the problem lies with the sensor cable, not the TrainSpeed 4 display unit. Dismount the sensor pair and inspect the connections between the cable and the optic, and the cable and the connector. Also look to see if the cable itself has been cut along its length. If you have a damaged sensor assembly or the swapping of sensors did not work, contact TDP & Associates for technical assistance.

Another problem that can occur is the unit powers up correctly but a train does not trigger the sensor properly. This can, on rare occasions, be caused by too much light (especially on the larger scales). It can also be caused by a short circuit in the sensor cable assembly. To check to see if there is too much light, put the unit in test mode for the sensor in question as outlined above, and cover the sensor completely and tightly with a dark opaque material (usually a hand pressed down firmly will do). If you see a change in the display from 'L' to 'H' then the sensor is working (if there is no change see the next paragraph). Now remove the cover and roll a train car across the sensor. If you do not see the display change or it does not stay 'H' while the car is over it then there is too much light. There are several ways to address this. You can recess the sensor further down into the mounting hole (even below the roadbed surface) to try to reduce the amount of light hitting the sensor. If this doesn't work you can use some black paint to reduce the area of the sensor's lens (ballast can be piled up around the sensor to do this too). Sometimes the sensor can pick up some excess light from floor reflections, so try covering the underside of the mounting hole with black tape. If these measures do not fix the problem contact TDP & Associates for technical assistance.

If the above test failed, then the sensor assembly is probably bad. First, try a different (previously working) sensor cable on the problem input. If that assembly works then inspect the problem sensor assembly for damage. Check to see if the leads on the optics have been bent such that they are shorting out (most likely caused while pushing the sensors up through the roadbed). Inspect the cable itself for damage as well. If you cannot get the sensor assembly working contact TDP & Associates for technical assistance.

If you do not get any display on the unit when you power it up, make sure that the intended voltage is present on the TrainSpeed 4's power terminals. If this voltage reads OK then try disconnecting all sensor cables and powering the unit up. If you get a display (you should see the 'oP.x' followed by 'Sn.E') then one of the sensor cables has been damaged. Plug them in one at a time until you isolate the problem cable. Inspect this cable for damage and contact TDP & Associates for a replacement if necessary.

Appendix

Extension cables

Extension cables can be made from normal male and female ten pin ribbon cable connectors and cable. An extension can be purchased from TDP & Associates or you can buy the parts from Digikey (www.digikey.com). Please note that Digikey has a \$25.00 minimum order (or else they will charge you an extra \$5.00). The necessary parts are:

Qty	P/N	Desc.
1	MPK10K-ND	10 pin plug connector
1	MSD10K-ND	10 pin socket connector
1	MC10G-X-ND*	ribbon cable

* The 'X' in the cable part number is 5, 10 or 25, which is how long the cable is in feet.

The cable is best assembled using a vise to crimp the connectors on the cable. Be sure to align the red stripe on the wire to the pin 1 indications on the connectors. Also make sure that the cable is 'square' to the connector.

Wall transformers

Radio Shack AC adaptors 273-1662 (set to 7.5V) or 273-1758 will work with this unit. Cut the plug that comes with the adaptor off and wire it directly into the power connector on the TrainSpeed 4 display unit.

FCC Information

Radio and TV Interference

(This information is required by the FCC)

This equipment has been tested and found to comply with the FCC class B digital device limits (part 15 of the FCC rules). These rules are meant to provide reasonable protection against harmful interference in a residential environment. This device generates and can radiate radio frequency energy. If the unit is not installed and operated as outlined in the users manual harmful interference may occur. However, there is no guarantee that interference will not occur in a particular installation. If interference occurs with radio and/or television reception (this can be determined by turning the unit on and off) the user is encouraged to try correcting the problem by:

- Reorient or relocate the receiving antenna.
- Increase the separation between the receiver and the unit.
- Connect the unit to a different outlet on a different circuit than the receiver.
- Consult the dealer and/or an experienced radio/TV technician for help.

Note that any modifications to the unit not expressly approved by TDP voids the users authority to operate under and be in compliance with the FCC CFR 47 rules. TDP believes that properly installed and operated equipment will be unlikely to cause RFI problems.

Warranty information

TDP & Associates guarantees the TrainSpeed 4 to be free of component and manufacturing defects for a period of one year after date of purchase. If a defect occurs return the product to TDP & Associates for service. TDP & Associates will repair or replace the TrainSpeed 4 at its discretion at no charge during the warranty period. This warranty excludes damage due to abuse, such as failure to properly install the unit, applying excessive input voltage to the unit or failure to provide protection against input over current with a fuse or circuit breaker.

TDP & Associates will make non-warranty repairs to the TrainSpeed 4 at reasonable and fair rates.

All warranties on this product are limited to refund of purchase price or repair or replacement of this product at the sole discretion of TDP & Associates.

In the event that this product is not installed or used in accordance with the manufacturer's specifications any and all warranties either expressed or implied are void. Except for what is expressly stated in this section there are no warranties, express or implied, including but not limited to any warranties of merchantability or fitness for a particular application.

TDP & Associates, Inc. reserves the right to make changes to this product's design or specifications, and/or to make improvements to this product without obligating TDP & Associates to install these changes, additions or improvements on previously manufactured products.

Contact information

TDP & Associates, Inc.

4 Jones Drive

Boothwyn, Pa. 19061

(610) 358-0460

www.trainspeed.com

email (preferred):

sales@trainspeed.com

info@trainspeed.com

©2002 TDP & Associates, Inc. All rights reserved.